



2ND EDITION

# NCF Kumho-Class Destroyer

<b>SPECS</b> Class: HCV In Service: ???? Point Value: Ramming Factor: 90 Jump Delay: N/A	<b>MANEUVERING</b> Turn Cost: 1x Speed Turn Delay: 3/4 Speed Accel/Decel Cost: 3 Thrust Pivot Cost: 3+3 Thrust Roll Cost: 3+2 Thrust		<b>COMBAT STATS</b> Fwd/Aft Defense: 14 Stb/Port Defense: 15 Engine Efficiency: 4/1 Extra Power: +0 Initiative Bonus: +6										
	Speed	1	2	3	4	5	6	7	8	9	10	11	12
	Turn Cost	1	2	3	4	5	6	7	8	9	10	11	12
	Turn Delay	1	2	3	3	4	5	6	6	7	8	9	9

<b>WEAPON DATA</b>	
<b>Bolt Cannon</b> Class: Projectile Modes: Standard Damage: 12 Range Penalty: -1 per hex Fire Control: +1/+1/-2 Intercept Rating: n/a Rate of Fire: 1 per 3 turns	⬢

<b>Light Bolt Cannon</b> Class: Projectile Modes: Standard Damage: 8 Range Penalty: -2 per hex Fire Control: +1/+0/+2 Intercept Rating: -1 Rate of Fire: 1 per 2 turns	⬢
---	---

<b>Gatling Cannon</b> Class: Projectile Modes: Raking (2) Damage: 2d3+2 Range Penalty: -3 per hex Fire Control: +4/+4/+4 Intercept Rating: -2 (vs Ballistic only) Rate of Fire: 1 per turn	⬢
--	---

<b>FORWARD HITS</b>	
1-3:	Retro Thrust
4-7:	Bolt Cannon
8-9:	Gatling Cannon
10-18:	Forward Structure
19-20:	PRIMARY Hit

<b>AFT HITS</b>	
1-7:	Main Thrust
8-9:	Gatling Cannon
10-18:	Aft Structure
19-20:	PRIMARY Hit

<b>PRIMARY HITS</b>	
1-7:	Primary Structure
8-11:	Lt Bolt Cannon
12-13:	Port/Stbd Thrust
14:	Sensors
15-16:	Engine
17-18:	Hangar
19:	Reactor
20:	C & C

**SPECIAL NOTES**  
Ammo Storage Level 2  
Antiquated Sensors  
Fission Reactor

<b>SENSOR DATA</b>	
Defensive EW	
Target #1	
Target #2	
Target #3	
Target #4	
Target #5	
Target #6	

Version 1.0: 2E/Fate

**MAIN HANGAR**  
6 Fighters  
1 Shuttle: Thrust: 3  
Armor: 0 Defense: 11/14  
████████

**CLASS SPECS**  
Number in Class: ??  
Manufacturer:  
*Undecided at this time,  
Someplace exciting*  
Out of Service: ???

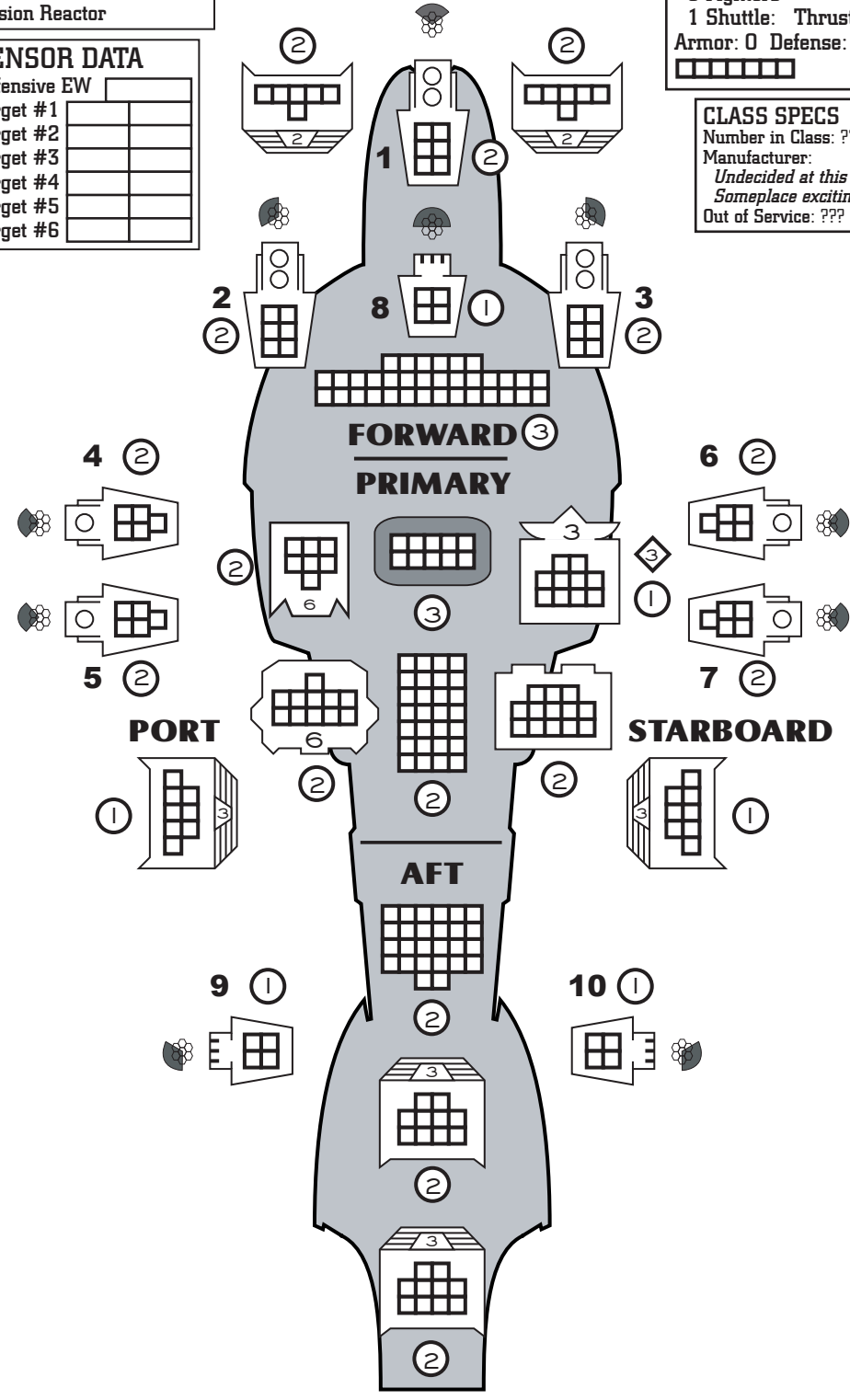

<b>ICON RECOGNITION</b>	
	Thruster
	C & C
	Sensors
	Engine
	Reactor
	Hangar
	Bolt Cannon
	Light Bolt Cannon
	Gatling Cannon